

## Performance Summary

- Philips Lumileds LED, high efficiency and 50,000 hours life span
- High efficiency LED Driver, with wide range input voltage 100-277VAC
- Cast Aluminium cooling design, superior light quality, LED Tj<85°C
- Excellent Optics design
- Photocell Control Available (Optional)

## Recommended Applications

Endless LED Half Cut-Off Wall Pack lighting series can be widely used indoor or outdoor. Applicable in wet locations.



Product Code:	ED-SCWP-45W277-XKB		
<b>Rated Power</b>	45W	<b>Input Voltage</b>	100-277VAC
<b>Lumen Flux</b>	4950 lm	<b>Lumens Per Watt</b>	110 lm
<b>Power Factor</b>	>0.95	<b>Driver Efficiency</b>	>90%
<b>CRI</b>	Ra>80	<b>Cable</b>	Input Connect, No Cable
<b>Color Temperature</b>	3000K / 4000K / 5000K	<b>Protection Level</b>	Wet Location/IP65
<b>Working Temperature</b>	-30°C to 45°C	<b>Storage Temperature</b>	-40°C to 80°C
<b>Lighting Angle</b>	60° x 90°	<b>LED Brightness Decay</b>	<5%/6000 hrs
<b>Life Span</b>	50,000hrs	<b>Shell Material</b>	Aluminum + PC
<b>Shell Color</b>	Dark Bronze		

## Dimensions

Fixture Dimensions (mm)	Net Weight	Units/Carton	Carton Dimension (mm)	Carton Weight
335x159x137	3kg /6.61lbs	1	395x225x205	3.5kg /7.72lbs

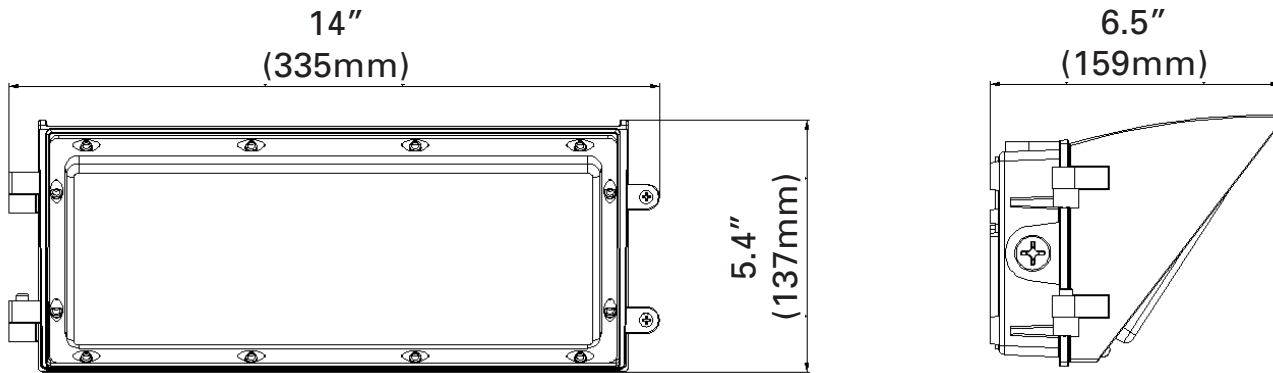

## Ordering Guide

ED	SCWP	45W	277	3K/4K/5K	P
Company Code	Fixture Type	Wattage	Voltage	Color	Dimmable

### Example - ED-SCWP-45W277-5K

Company	Product	Wattage	Voltage	Color	Photocell
ED Energy Dynamics	SCWP Semi cut-off Wallpack	45W 45watts	277 100-277VAC	3K 3000K 4K 4000K 5K 5000K	P Photocell (Optional)

## Notice For Users

- These fixtures must be installed by a licensed electrician.
- Turn off power before installing or changing fixture and or assembly parts.
- The facility input voltage has to be within the same range as the line voltage of the fixture.

### Warranty

This product has a warranty period of 5 years from date of purchase. The warranty is invalid in case of improper use, improper installation, tampering, removal of the Q.C. date label, installation in an improper working environment or installation not according to the current edition of the National Electric Code. Should this product fail during warranty period it will be replaced free of charge, subject to return of the faulty unit. Energy Dynamics does not accept responsibility for any installation costs associated with the replacement of the product. Energy Dynamics reserve the right to alter specification without prior notice.