

Advantages

- High efficiency LED driver with wide range input voltage 120-277VAC or 200-480VAC
- 120 Lumens per watt and life span of over 50,000 hrs
- Cast aluminium design with high efficiency cooling and easier replacement
- Excellent optical design greatly improve light utilization and evenness
- Photocell control available (Option)
- 5 year mfg. warranty



Application

Our LED Shoebox fixture can be widely used in Urban roads, Industrial areas, Residential areas, Sidewalks, Parking lots, Schools, etc.

Specification

Product Code:	ED-SB200WXXX-XKD-TX-X-P		
Rated Power	200W	Lighting Angle	Type 2, Type 3, Type 5
Input Voltage	AC120-277V / AC200-480V	LED Brightness Decay	<5% / 6000 hrs
PF	>0.95	Life Span	>50,000 hrs
Driver Efficiency	>90%	Working Temperature	-30 to +45°C
Luminous Flux	22,100lm	Storage Temperature	-40 to +80°C
Color Temperature	3000K / 4000K / 5000K	Protection Level	IP65
CRI	Ra>80	Cable	3 Core, 18AWG
Shell Material	Aluminum & PC.	Finish	Dark Bronze

Dimensions

Fixture Dimensions	Net Weight	Units/Carton	Carton Dimension	Carton Weight
23.7" x 11.13" x 3.34"	7.5kg / 16.60lbs	1	25.9" x 16.53" x 8.1"	10.0kg / 22.05lbs

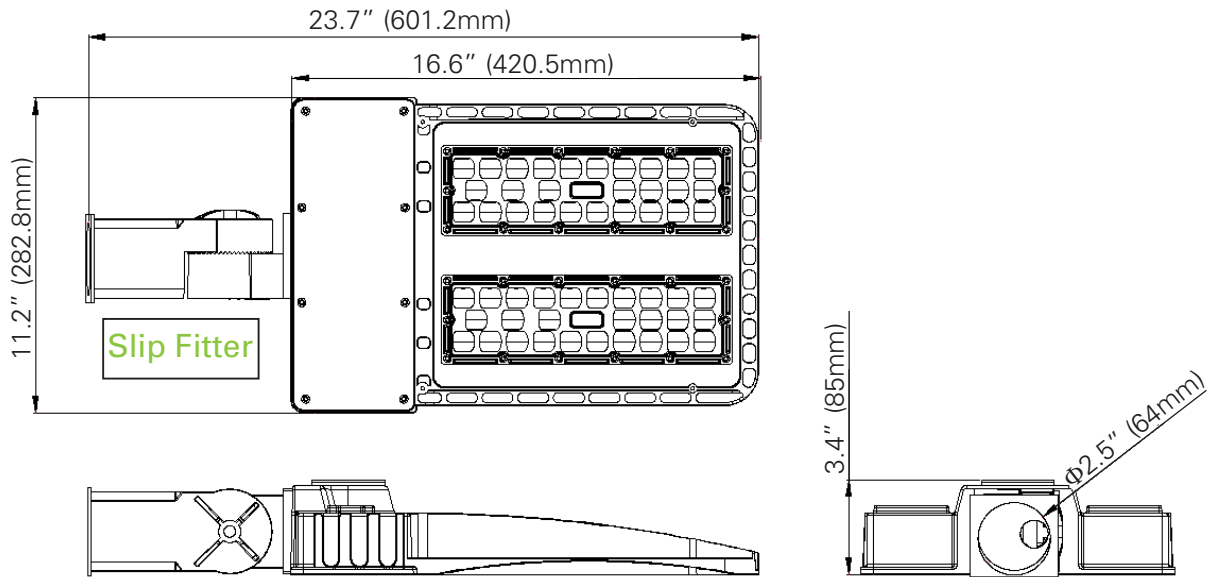

Photometry and Type 5:

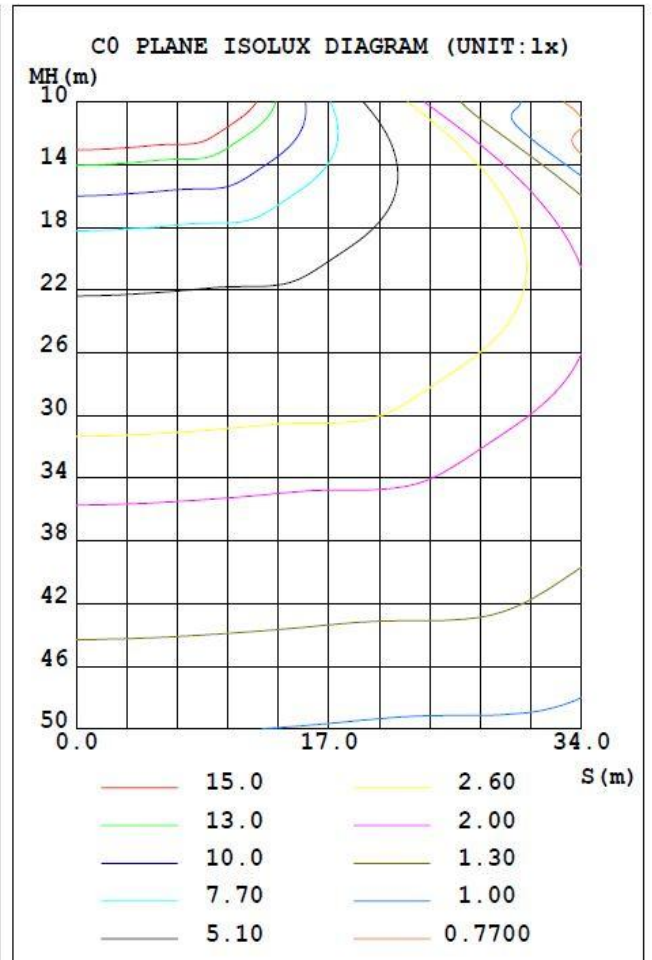
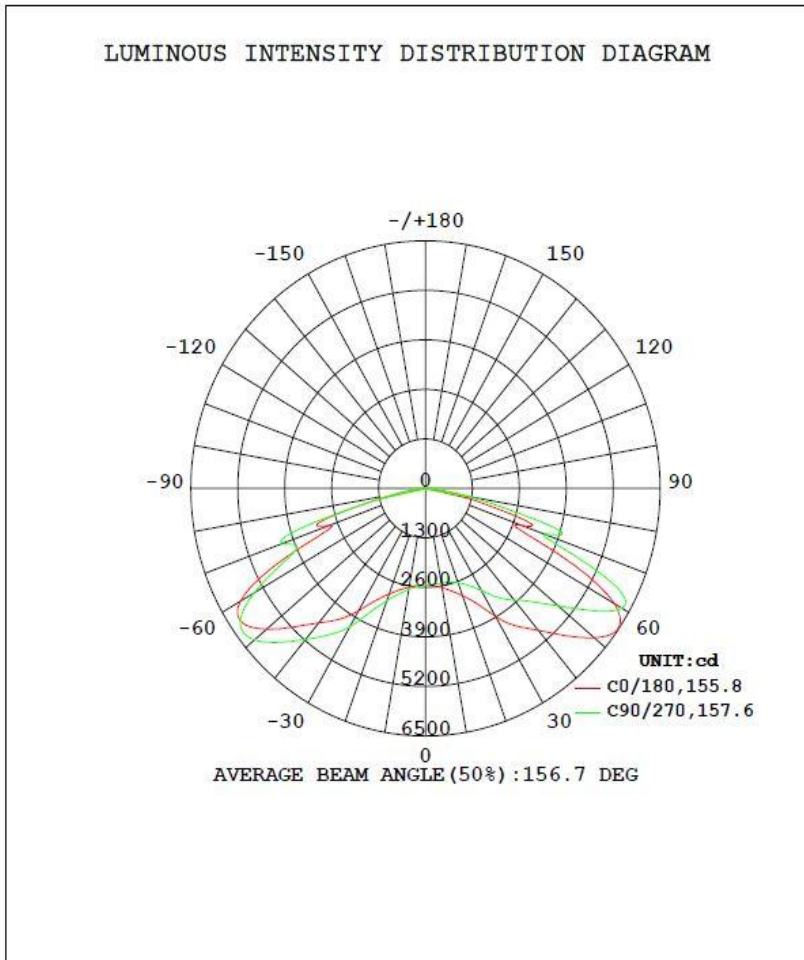

Ordering Guide

ED	SB	200W	277/480	3K/4K/5K	D	T3/T5	S/T/A	P
Company Code	Fixture Type	Wattage	Voltage	Color	Finish	Type	Mount	Control

Example - EDSB-200W480-5KD-T3-S

Company	Product	Wattage	Voltage	Color	Finish	Type	Mount	Control
ED Energy Dynamics	SB Shoebox	200W 200watts	277 AC120-277V	3K 3000K	D Dark Bronze	T3 Type 3	S Slip Fitter	P Photocell
			480 AC200-480V	4K 4000K		T5 Type 5	T Trunion	
				5K 5000K			A Arm	

Mounting Guide

1 S: SLIP FITTER MOUNTING

Dimension of the slip fitter

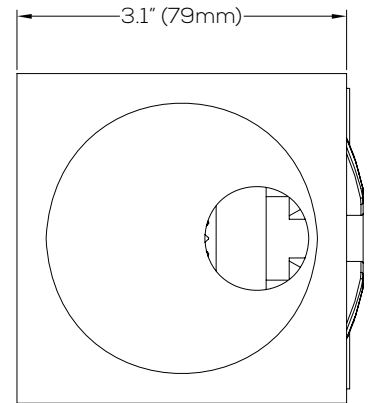
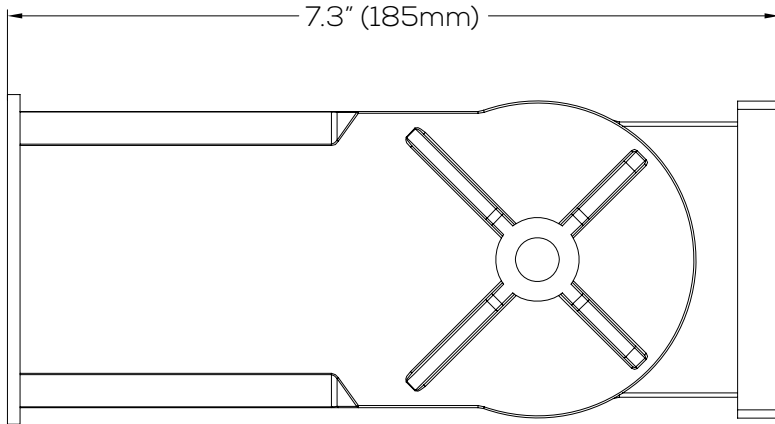

Step 1

Connect the AC wire, and then insert the arm of the slip fitter to the pole.

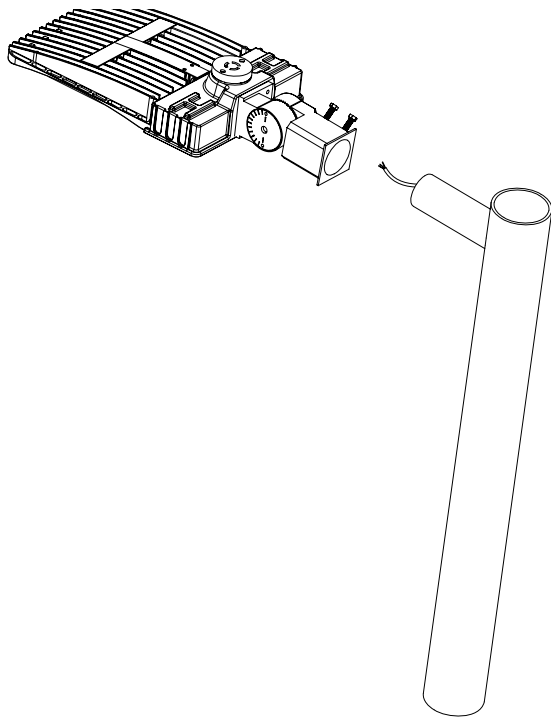

Step 2

Tighten the screws on the side of the arm and then power on.

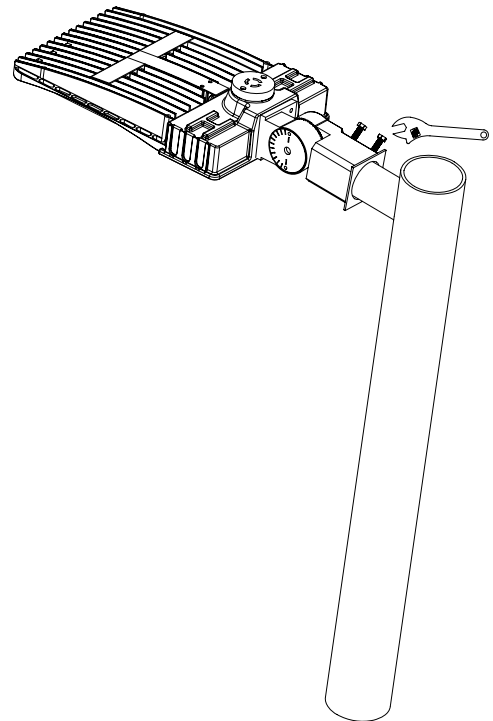

2 T: TRUNNION MOUNTING

Dimension of the trunnion

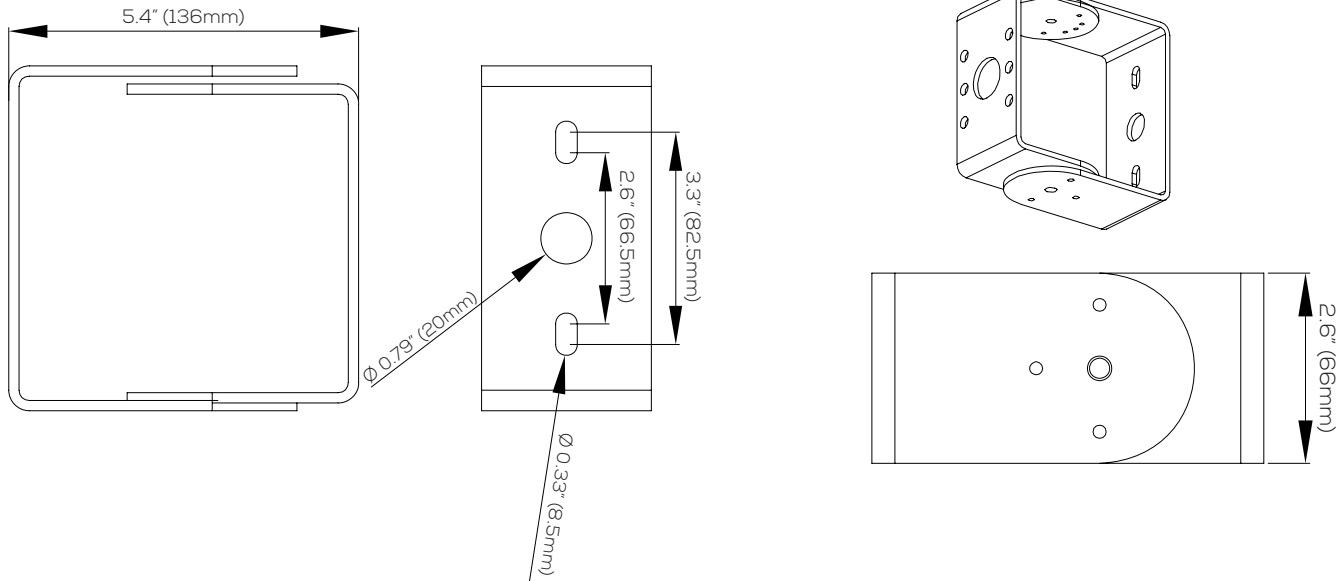

Step 1

Drill two holes on the wall corresponding to the holes on the trunnion, and knock expansion screws into the holes.

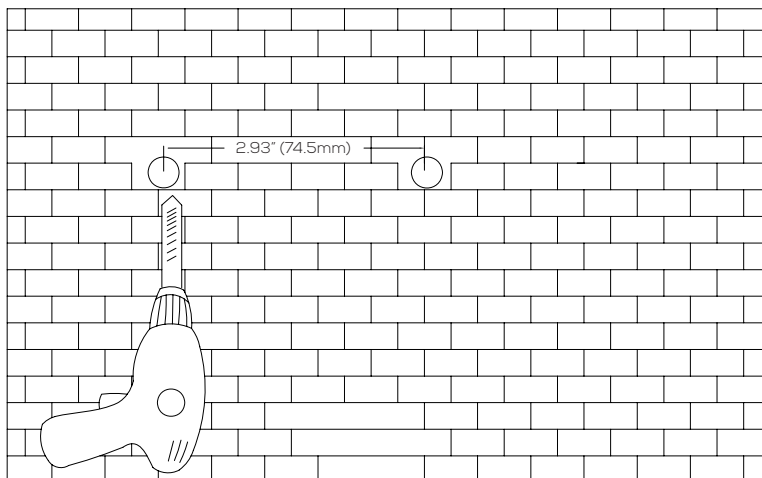

Step 2

Use the nuts to fix the fixture to the wall aiming at the expansion screws, and adjust angle of the bracket and tighten the small screw on the side then connect the AC wire.

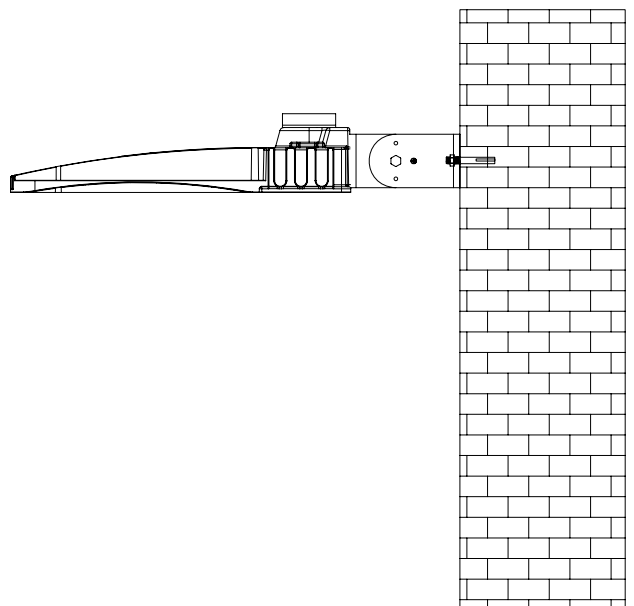

3 A1: ARM MOUNTING FOR SQUARE POLE

Arm dimension

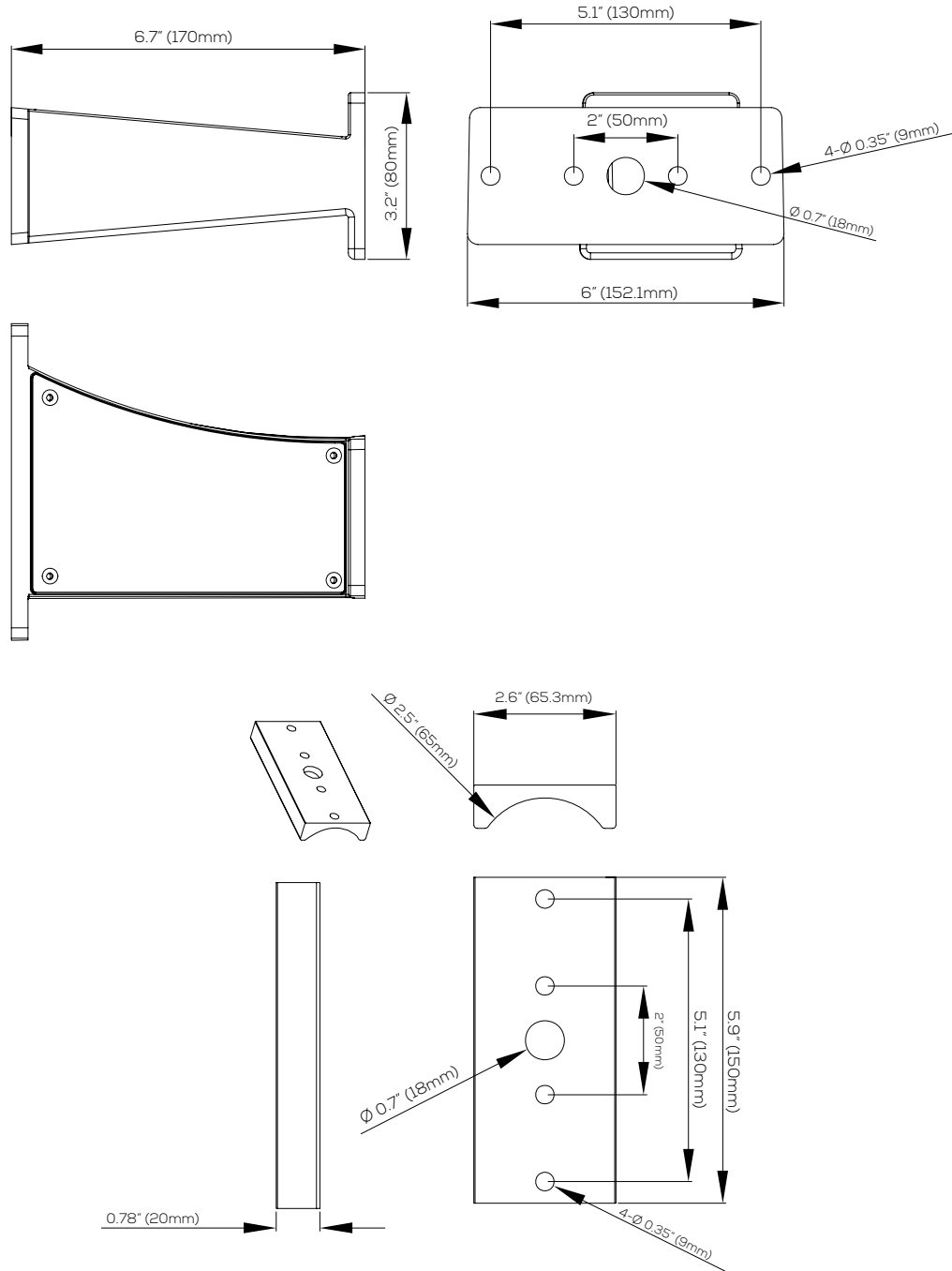

Arm assembly drawing

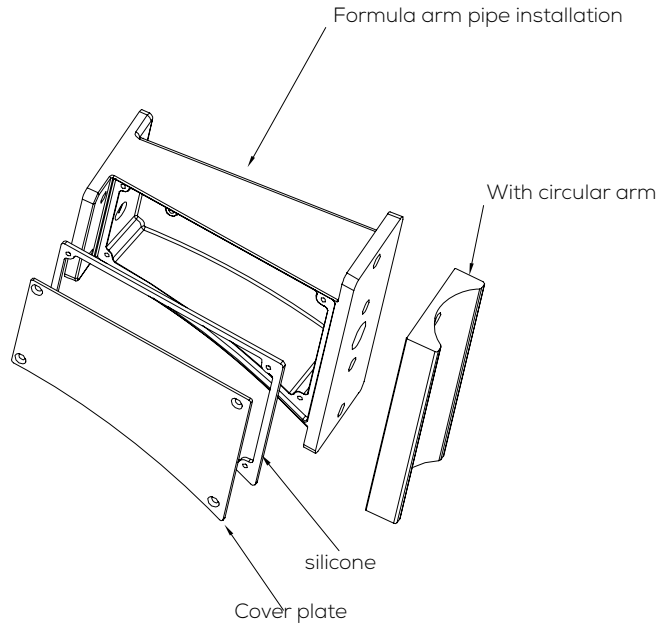

Step 1

Drill holes on the square pole corresponding to the holes on the arm, and use the bolt and nut plate to fix the fixture to the pole tightly.

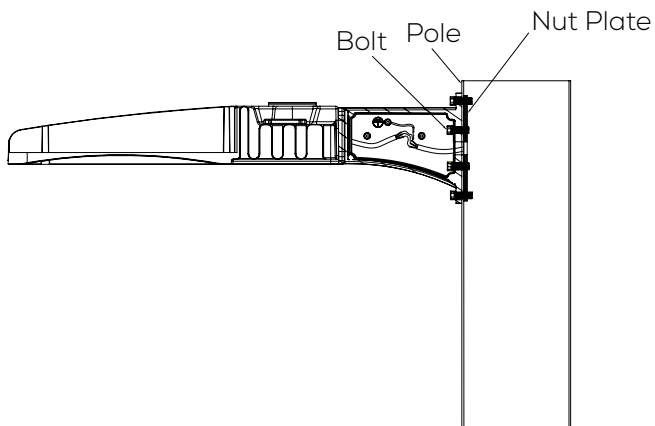

Step 2

Connect the AC wire of the fixture and tighten the water-proof gasket and cover plate on the arm by screws, then power on.

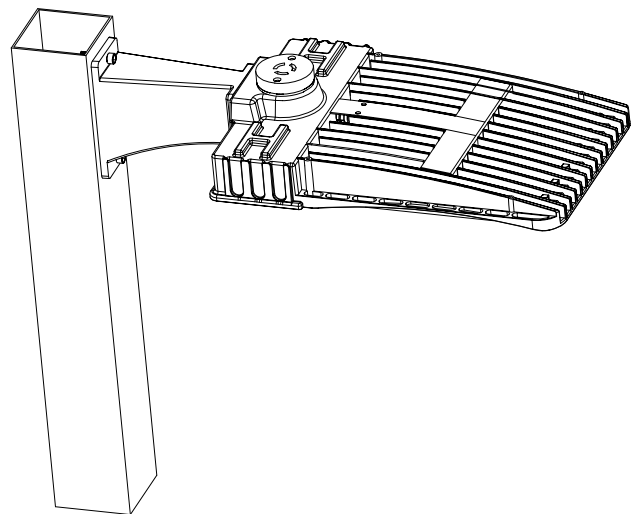

4 A2: ARM MOUNTING FOR ROUND POLE

Step 1

Drill holes on the round pole corresponding to the holes on the arm, and use the bolt and nut plate to fix the fixture to the pole tightly.

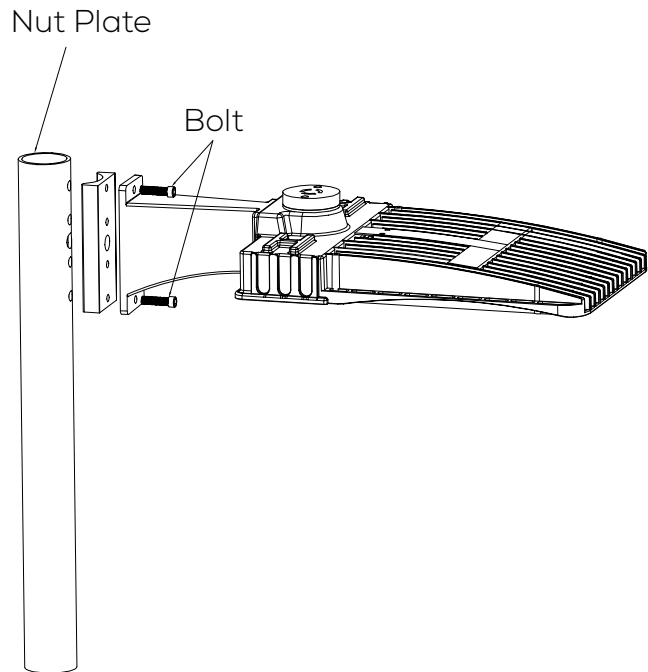

Step 2

Connect the AC wire of the fixture and tighten the water-proof gasket and cover plate on the arm by screws, then power on.

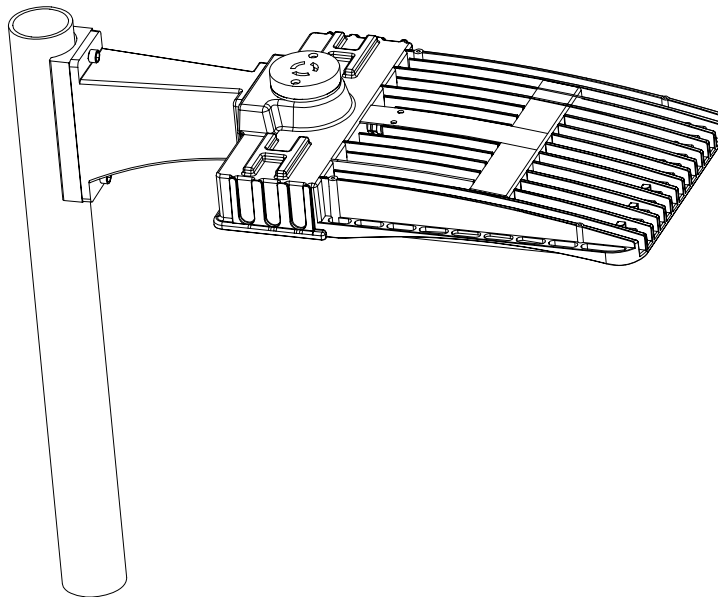

WARNINGS AND CAUTIONS

- The product Must be installed by a licensed electrician.
- Turn the power off before installing this fixture
- Do not drill holes in the fixture or change the internal wiring of the fixture
- For assistance please contact a customer service representative.

Warranty

This product has a warranty period of 5 years from date of purchase. The warranty is invalid in the case of improper use, improper installation, tampering, removal of the Q.C. date label, installation in an improper working environment or installation not according to the current edition of the National Electric Code. Should this product fail during warranty period it will be replaced free of charge, subject return of the faulty unit. Energy Dynamics does not accept responsibility for any installation costs associated with the replacement of the product. Energy Dynamics reserve the right to alter specification without prior notice.